

# HR | HALF SQUAT RACK -70 | WITH PULL UP BAR

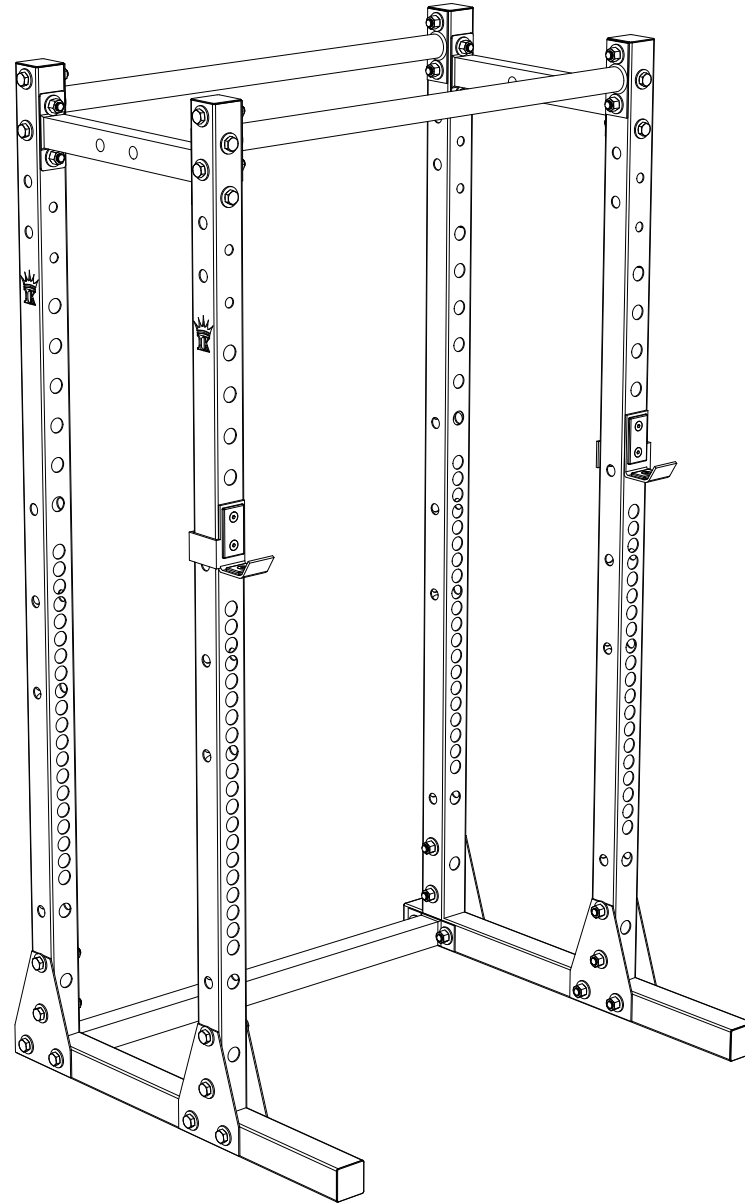

*#trainincolour*

# HR-70 | PRODUCT SPECIFICATION



## WARNING

*TO AVOID POSSIBLE HARM, READ AND FOLLOW THIS ADVICE AND THE FOLLOWING INSTRUCTIONS.*

MISUSE OF THE EQUIPMENT OR INCORRECT ASSEMBLY MAY RESULT IN SERIOUS OR FATAL INJURY.

ENSURE THAT ALL PARTS ARE UNDAMAGED AND IN WORKING ORDER BEFORE ATTEMPTING TO USE THE PRODUCT.

ENSURE NUTS AND BOLTS ARE TIGHT AND THAT ALL PARTS ARE PLUMB BEFORE USE.

WE RECOMMEND A MINIMUM OF 2 PEOPLE FOR SAFE ASSEMBLY OF THE PRODUCT.

WEAR APPROPRIATE P.P.E. WHILE ASSEMBLING.

<b>MAX TRAINING WEIGHT</b>	350KG
<b>PRODUCT WEIGHT</b>	70KG
<b>DIMENSIONS</b>	1.2M x 1.2M x 2.25M
<b>PRODUCT FOOTPRINT</b>	1.2M x 1.2M

# HR-70 | PARTS LIST



## TOOLING

19MM SPANNER  
STEP LADDER

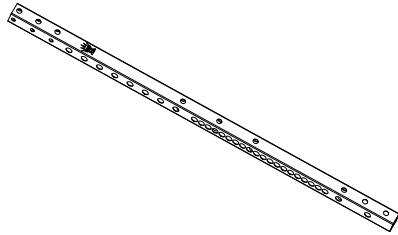

x4 UPRIGHTS [1]

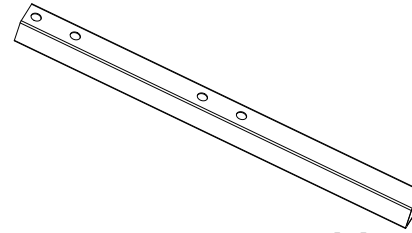

x2 BASE FEET [2]

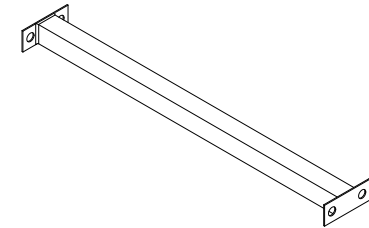

x1 BASE HORIZONTAL [3]

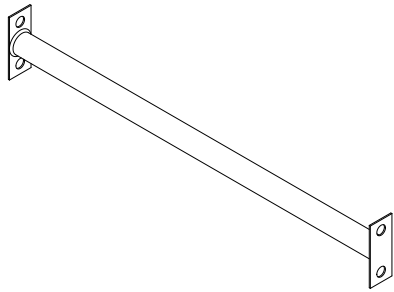

x2 PULL UP BARS [4]

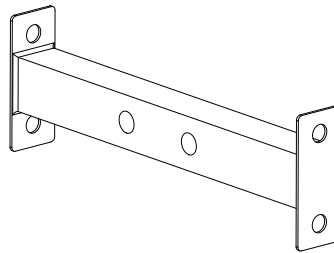

x2 CROSS MEMBERS [5]

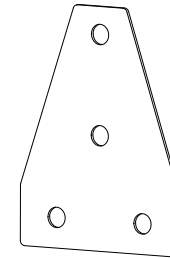

x6 BRACE PLATE [6]

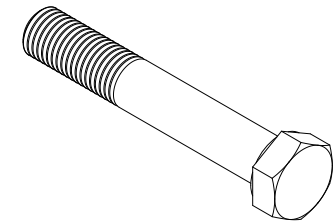

x32 M12 BOLT [7]

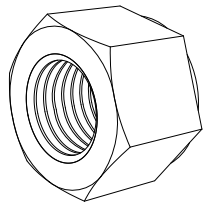

x32 M12 NUT [8]

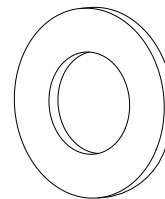

x64 M12 WASHER [9]

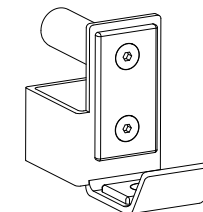

x2 'J' HOOKS [10]

# STEP 1 | ASSEMBLY

USE x4 BOLTS [7], x4 NUTS [8] AND x8 WASHERS [9] TO ATTACH TOGETHER THE BASE HORIZONTAL [3], x2 FEET [2] AND x2 BRACE PLATES [6].

LINE THE PARTS UP WITH THE TWO END HOLES ON THE BASE FEET AND ENSURE THAT THE BRACE PLATES ARE ON THE OUTSIDE OF THE RACK.

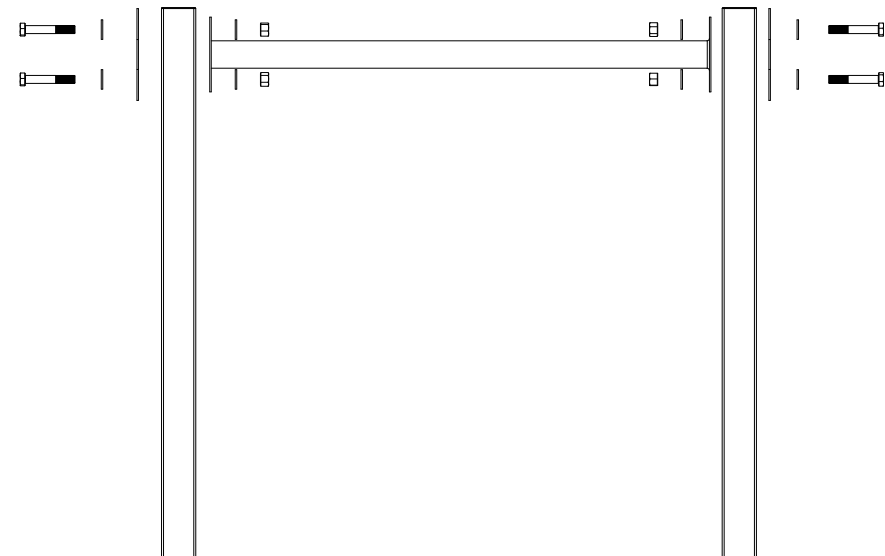
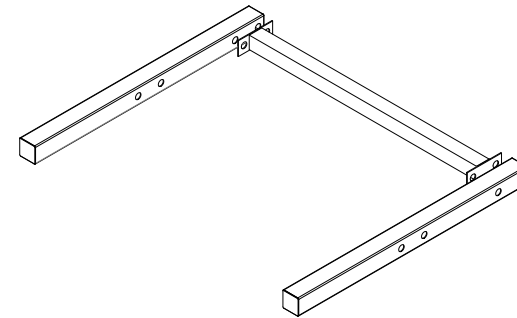

## REQUIRED

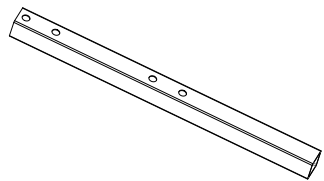

x2 [2]

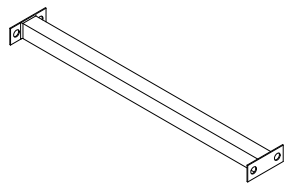

x1 [3]

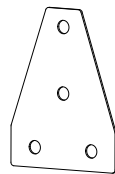

x2 [6]

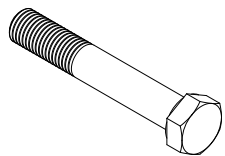

x4 [7]

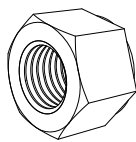

x4 [8]

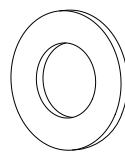

x8 [9]

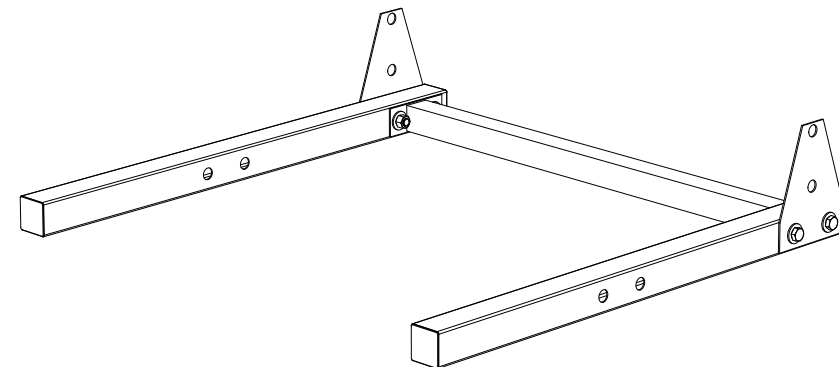

# STEP 2 | ASSEMBLY



ATTACH x2 UPRIGHTS [1] TO APPROX THE MIDDLE OF THE BASE FEET. FASTEN TOGETHER USING x4 BRACE PLATES [6], x8 BOLTS [7], x8 NUTS [8] AND x16 WASHERS [9].

ATTACH x2 UPRIGHTS TO THE BACK OF THE TWO BASE FEET, IN LINE WITH THE TWO BRACE PLATES.

FASTEN TOGETHER USING x4 BOLTS [7], x4 NUTS [8] AND x8 WASHERS [9].

ENSURE THE SHORTEST FACE OF THE BRACE PLATES ARE FACING UP AND THE IRON KING LOGOS ARE AT THE TOP END AND FACING OUTWARD FROM THE RACK.

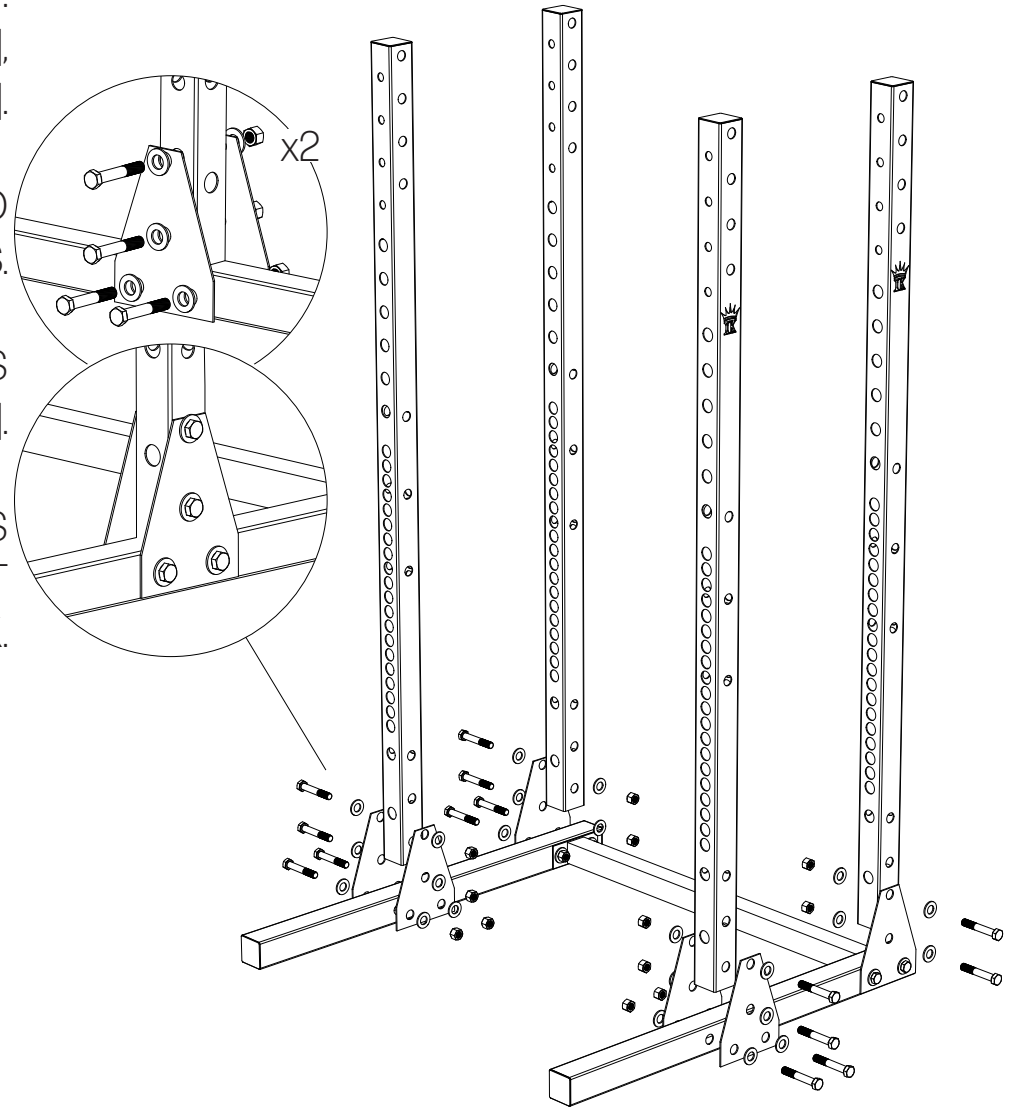

## REQUIRED

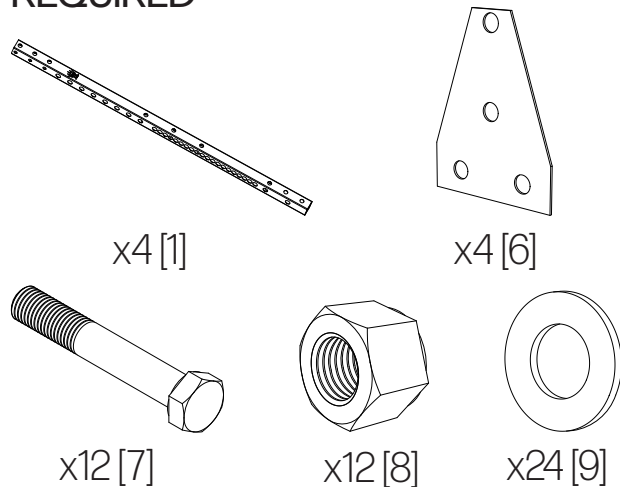

# STEP 3 | ASSEMBLY



FIX THE x2 CROSS MEMBERS [5] BETWEEN THE FRONT AND BACK UPRIGHTS.

FASTEN TO THE TOP HOLES OF THE UPRIGHTS USING x8 BOLTS [7], x8 NUTS [8] AND x16 WASHERS [9].

## REQUIRED

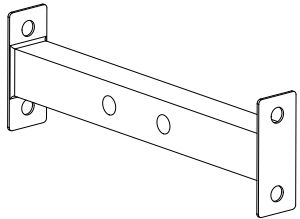

x2 [5]

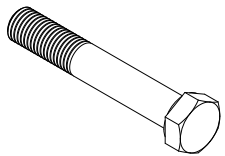

x8 [7]

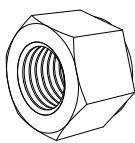

x8 [8]

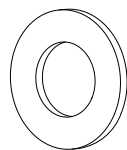

x16 [9]

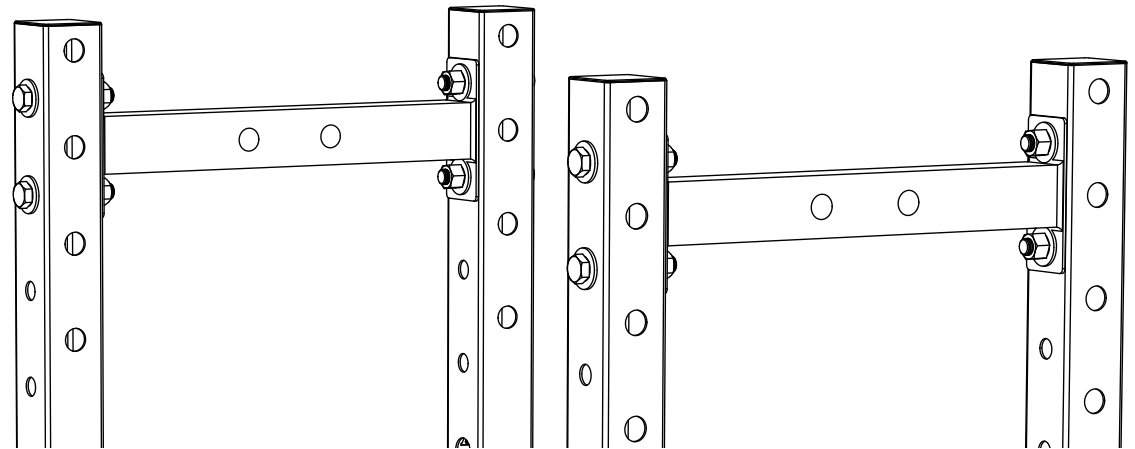

# STEP 4 | ASSEMBLY

FIX THE x2 PULL UP BARS [4] TO ANY OF THE TWO HOLES AT THE TOP OF THE x2 UPRIGHTS.

FASTEN TOGETHER USING x8 BOLTS [7], x8 NUTS [8] AND x16 WASHERS [9].

## REQUIRED

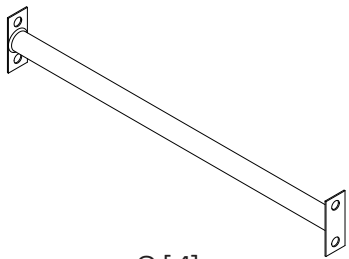

x2 [4]

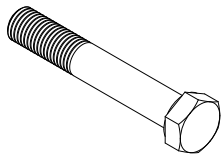

x8 [7]

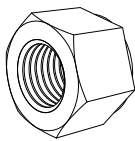

x8 [8]

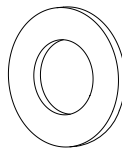

x16 [9]

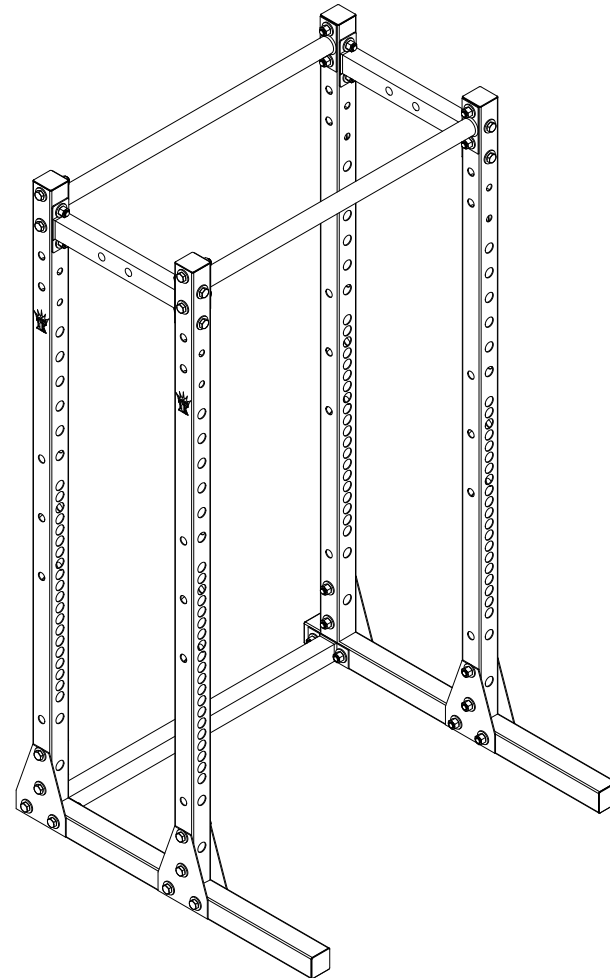
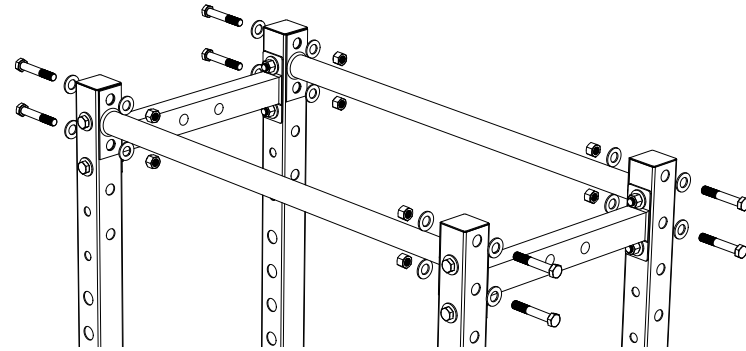

# STEP 5 | ASSEMBLY

ATTACH THE x2 'J' HOOKS [10] TO THE UPRIGHTS.

HOLD THE 'J' HOOK UPRIGHT SO THAT IT LOOKS LIKE A 'J'. TURN THE 'J' HOOKS TO THE SIDE AND PLACE THE PIN INTO A HOLE ON THE FRONT OF THE RACK.

THE HOOK CAN NOW BE TURNED BACK UPRIGHT SO THAT IT SITS FLUSH WITH THE UPRIGHTS.

REPEAT THIS STEP FOR THE OTHER 'J' HOOK, ENSURING THAT THEY LINE UP WITH EACH OTHER.

## REQUIRED

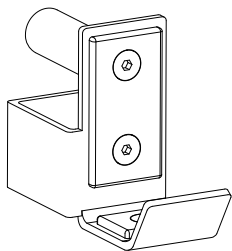

x2 [10]

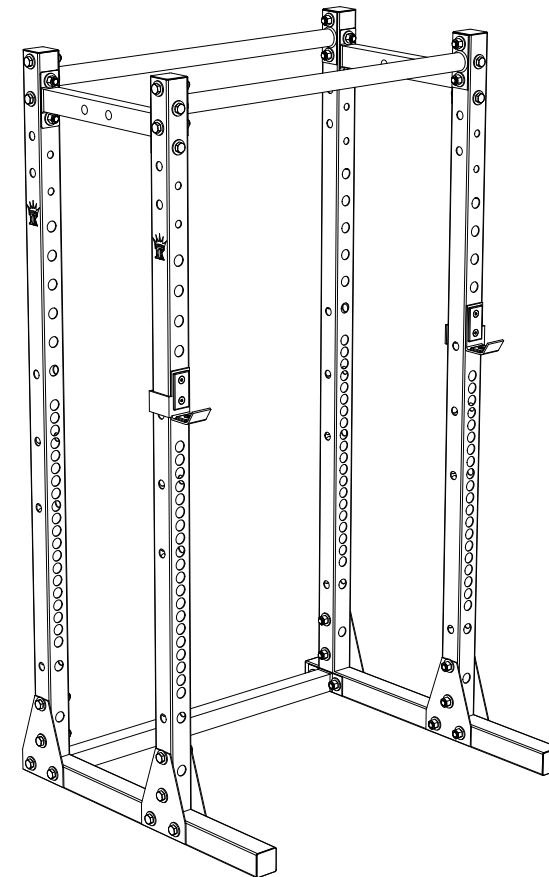
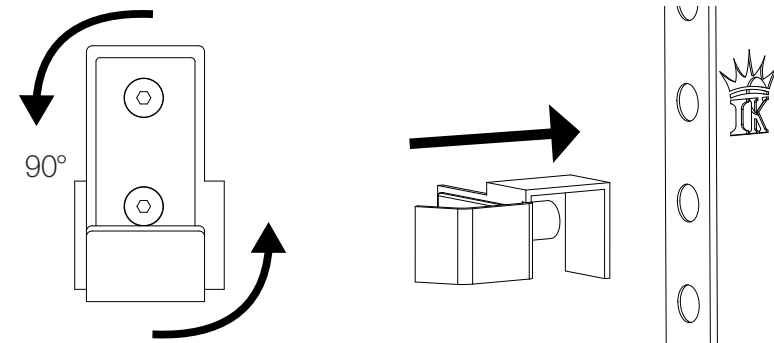



FOLLOW

 Iron King

 @iron\_king\_gym equipment

#trainincolour

REVIEW

 Google  
★★★★★ Reviews

 ★ Trustpilot  
★★★★★

CONTACT

 [www.ironking.uk.com](http://www.ironking.uk.com)

 [sales@ironking.uk.com](mailto:sales@ironking.uk.com)

 0121 326 9902